

# GRAND OPENINGS BY UDI, INC

## STEPS TO ORDERING

1. Choose your style:

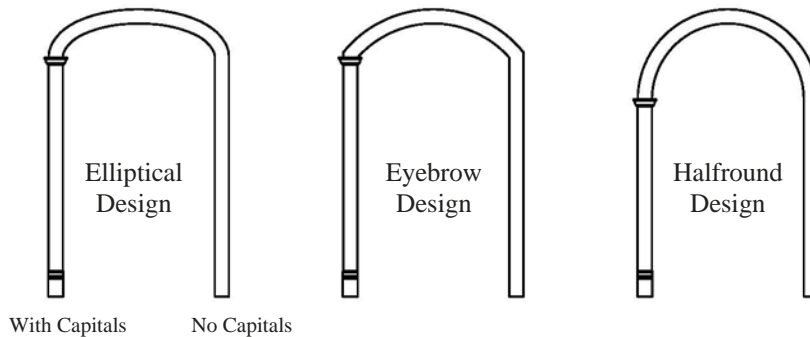

### Horizontal Extension Design

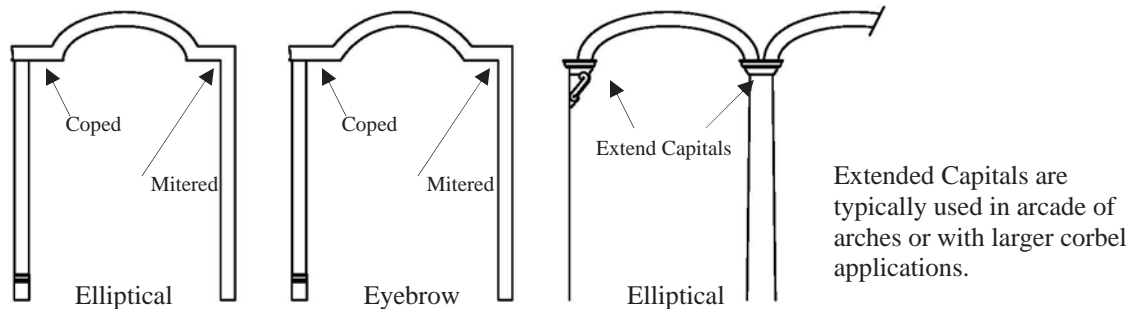

2. Choose your Rise:

- 12” or 20” (20” rise is only suggested for ceilings heights 10’ and greater, see page 6)

3. Choose your Model Size (see diagram, “W”):

- The Model Size is determined by the Rough Opening Width
  - Elliptical Design (see page 15-16)
  - Eyebrow Design (see page 20-21)
  - Halfround Design (see page 22)
  - Horizontal Extension Design (see page 25-36)

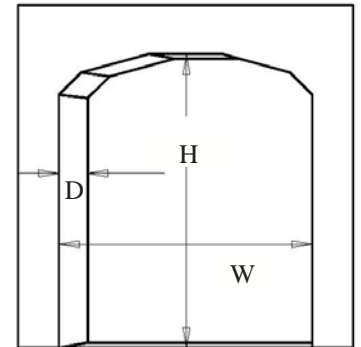

4. Choose your Finished Wall Thickness:

- See Diagram, “D” (Be sure to include sheetrock in thickness)

5. Choose your Profile (See Page 8-9):

6. Choose your Decorative Accents (Please refer to page 37 for compatibility) :

- Capital (Optional,p.8)
- Backband (Optional,p.9)
- Keystone Style (Mandatory for Model Sizes 108 and Larger)
- Recessed Panel (Optional for Wall Thickness 6 9/16” and greater, see page 10-11)
- Round Fluted Pilaster (Optional, see pages 8-9)

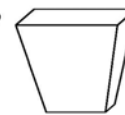
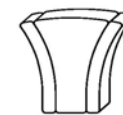
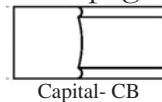
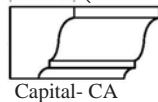

7. Header Height (see diagram, “H”)

8. Start your project, Refer to Framing Instructions starting on page 14. Single page framing instructions for each Model Size are available on our website.

